

40 YEARS OF CONTINUOUS INNOVATION



GARNIGA

OUR GLOBAL VISION AT YOUR SERVICE



2006

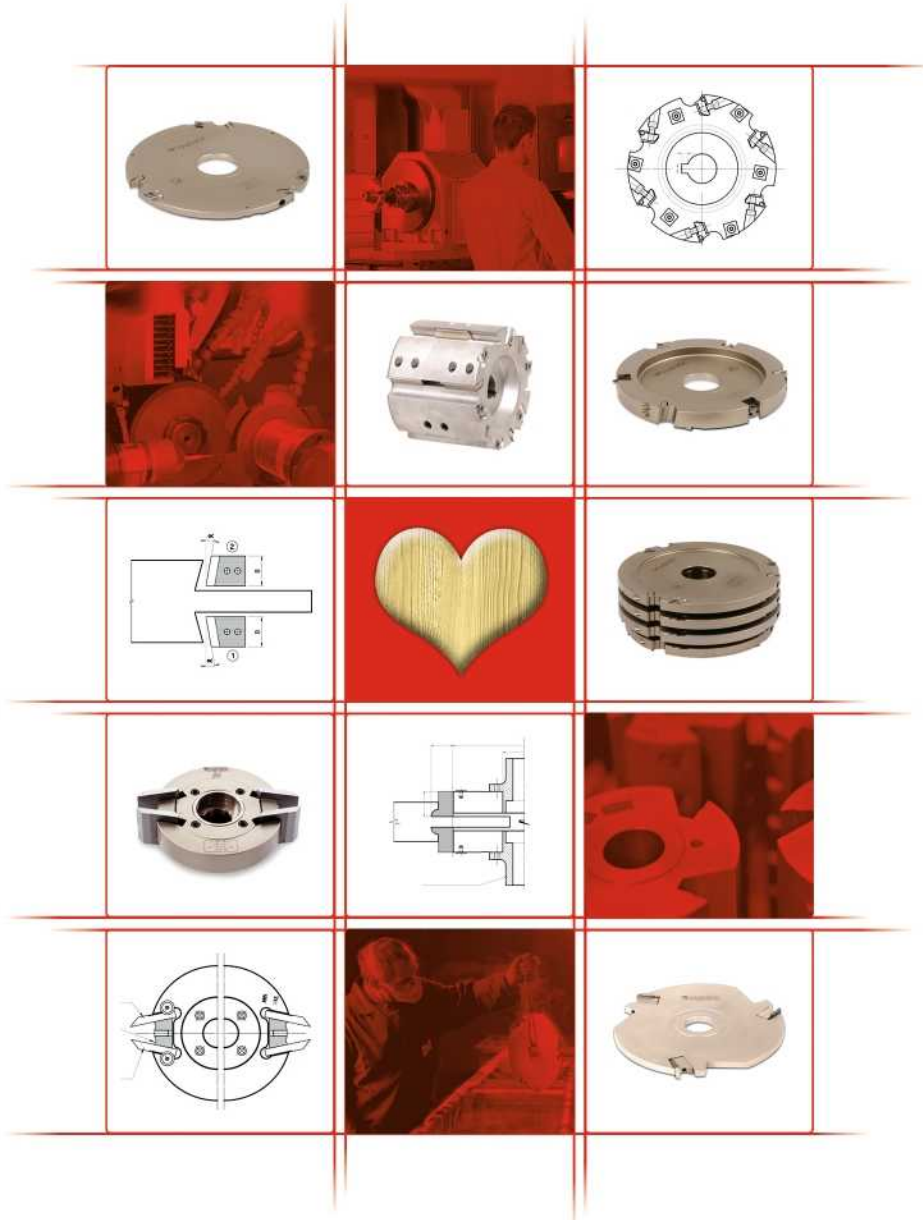

-  **TENONARE**
-  **TENONING**
-  **ESPIGADO**
-  **ZAPFENBEARBEITUNG**

TENONARE Tenoning Espigado Zapfenbearbeitung

pag.143	art. 03	100
pag.145	art. 03	104
pag.146	art. 03	104
pag.147	art. 04	141
pag.148	art. 04	142
pag.149	art. 15	105

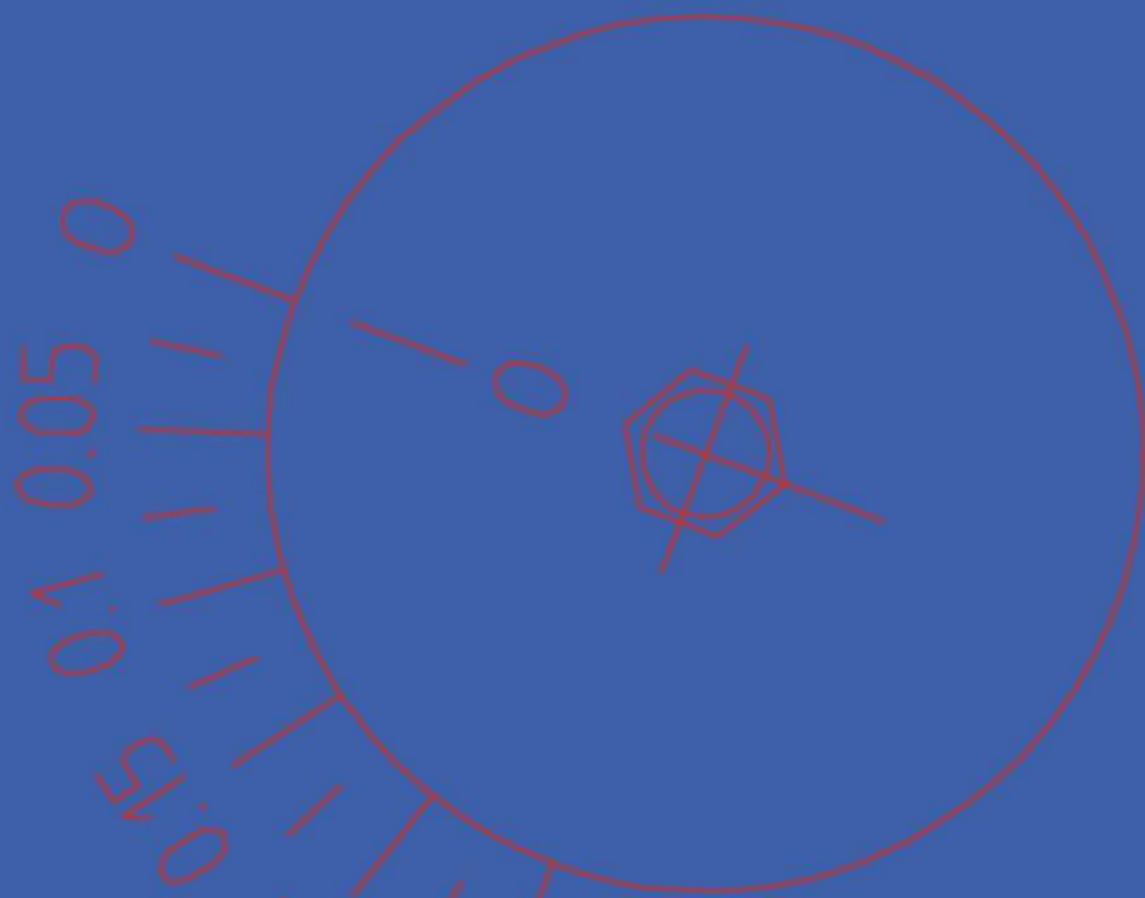

03 100 TENONARE Tenoning Espigado Zapfenbearbeitung



DISCHI A TENONARE SEMIREGISTRABILI

Dischi a tenonare con diametro di taglio variabile. Possibilità di montare sia taglienti dritti, inclinati o sagomati

SEMI-ADJUSTABLE TENONING DISKS

Tenoning disks with variable diameter. Possibility of use straight, inclined or profiled knives

PLATO DE ESPIGAR SEMI-REGULABLE

Plato de espigar con diámetro de corte variable. Posibilidad de montar cuchillas ranuradas rectas, inclinadas o perfiladas

TEILVERSTELLBARE VERZAPFSCHEIBEN

Verzapfscheiben mit verstellbarem Schneiddurchmesser.

Es besteht die Möglichkeit gerade, schräge oder Profilierte Messer einzusetzen

Articolo	Z	D min-max	B min-max	XX	RPM min-max
03 100 2200200 25	3	220-230	8-16	30-31.75-35-40-50-60	3600-5300
03 100 2200300 25	3	220-230	12-25	30-31.75-35-40-50-60	3600-5300
03 100 2300300 25	3	230-240	8-16	30-31.75-35-40-50-60	3400-5000
03 100 2300400 25	3	230-240	12-25	30-31.75-35-40-50-60	3400-5000
03 100 2400500 25	3	240-250	8-16	30-31.75-35-40-50-60	3300-4900
03 100 2400600 25	3	240-250	12-25	30-31.75-35-40-50-60	3300-4900
03 100 2500700 25	3	250-260	8-16	30-31.75-35-40-50-60	3100-4700
03 100 2500800 25	3	250-260	12-25	30-31.75-35-40-50-60	3100-4700
03 100 2601400 25	3	260-270	8-16	30-31.75-35-40-50-60	3000-4500
03 100 2601500 25	3	260-270	12-25	30-31.75-35-40-50-60	3000-4500
03 100 2700100 25	3	270-280	8-16	30-31.75-35-40-50-60	2900-4400
03 100 2700200 25	3	270-280	12-25	30-31.75-35-40-50-60	2900-4400
03 100 2800100 25	3	280-290	8-16	30-31.75-35-40-50-60	2800-4200
03 100 2800200 25	3	280-290	12-25	30-31.75-35-40-50-60	2800-4200
03 100 2900500 25	3	290-300	8-16	30-31.75-35-40-50-60	2700-4100
03 100 2900600 25	3	290-300	12-25	30-31.75-35-40-50-60	2700-4100
03 100 3000100 25	3	300-310	8-16	30-31.75-35-40-50-60	2600-4000
03 100 3000200 25	3	300-310	12-25	30-31.75-35-40-50-60	2600-4000

03 100 RICAMBI	Spare parts	Parte de repuestos	Ersatzteile
Codice	Descrizione		Dimensione
10 106 0000700		Tassello semireg. (v.8-16 mm)	19,5x7mm
08 101 0505030		Vite fissaggio tagliente	M5x30 mm
10 106 0000701		Tassello semireg. colt. 5,5mm (v.12-15mm)	19,5x9mm
10 106 0000702		Tassello semireg. colt. 8mm (v.12-15mm)	16,5x9mm
08 101 0108025		Grano fissaggio tagliente	M8x25 mm
08 101 0105016		Grano regolazione tagliente	M5x16 mm

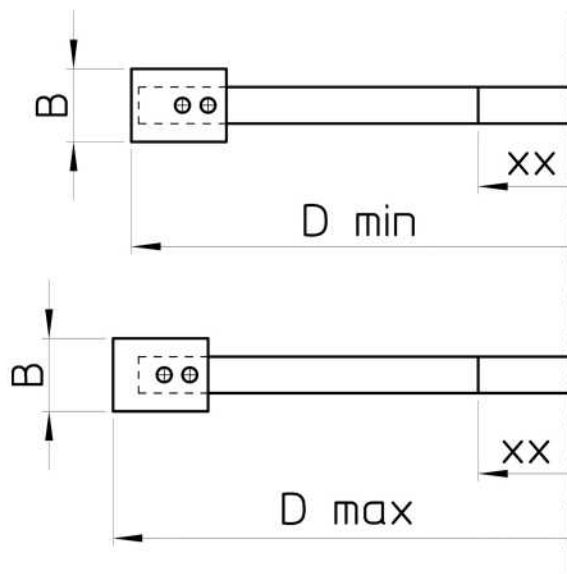

03 100



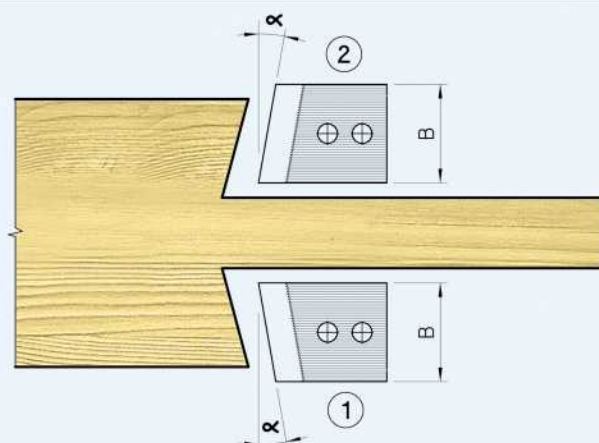

TAGLIENTE PROFILO INCLINATO				
Articolo		B (mm.)	α	S (mm.)
1	2			
06 105 8811200	06 105 8811201	8	10°	5,5
06 105 8811202	06 105 8811203	9	10°	5,5
06 105 8811204	06 105 8811205	10	10°	5,5
06 105 8811206	06 105 8811207	12	10°	5,5
06 105 8811208	06 105 8811209	16	10°	8
06 105 8811210	06 105 8811211	18	10°	8
06 105 8811212	06 105 8811213	22	10°	8
06 105 8811214	06 105 8811215	8	18°	5,5
06 105 8811216	06 105 8811217	9	18°	5,5
06 105 8811218	06 105 8811219	10	18°	5,5
06 105 8811220	06 105 8811221	12	18°	5,5
06 105 8811222	06 105 8811223	15	18°	5,5
06 105 8811224	06 105 8811225	16	18°	8
06 105 8811226	06 105 8811227	18	18°	8
06 105 8811228	06 105 8811229	22	18°	8

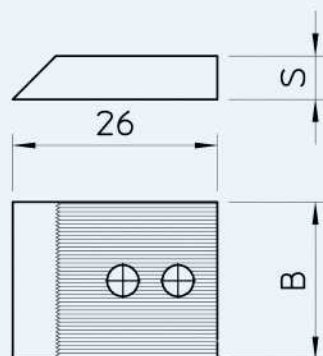

TAGLIANTI PROFILO DRITTO		
Articolo	B (mm.)	S (mm.)
06 105 8811150	8	5,5
06 105 8811151	9	5,5
06 105 8811152	10	5,5
06 105 8811153	12	5,5
06 105 8811154	15	5,5
06 105 8811155	16	5,5
06 105 8811156	18	5,5
06 105 8811157	20	5,5
06 105 8811158	22	5,5
06 105 8811159	25	5,5
06 105 8811160	30	5,5
06 105 8811161	35	5,5

03 104 TENONARE Tenoning Espigado Zapfenbearbeitung

Type 01



Articolo	D	B	Z	V	LS	Pos.	XX	RPM min-max
03 104 2600800 45	260	20	3	3	3	2	30-31,75-35-40-50-60	3000-4500
03 104 2600900 45	260	20	3	3	3	1	30-31,75-35-40-50-60	3000-4500
03 104 2600100 45	260	30	3	3	3	1	30-31,75-35-40-50-60	3000-4500
03 104 2600200 45	260	30	3	3	3	2	30-31,75-35-40-50-60	3000-4500
03 104 2681400 45	268	20	3	3	3	2	30-31,75-35-40-50-60	2900-4400
03 104 2681500 45	268	20	3	3	3	1	30-31,75-35-40-50-60	2900-4400
03 104 2680400 45	268	30	3	3	3	2	30-31,75-35-40-50-60	2900-4400
03 104 2680500 45	268	30	3	3	3	1	30-31,75-35-40-50-60	2900-4400
03 104 2740300 45	274	20	3	3	3	1	30-31,75-35-40-50-60	2900-4400
03 104 2740400 45	274	20	3	3	3	2	30-31,75-35-40-50-60	2900-4400
03 104 2740500 45	274	30	3	3	3	1	30-31,75-35-40-50-60	2900-4400
03 104 2740600 45	274	30	3	3	3	2	30-31,75-35-40-50-60	2900-4400
03 104 3040300 45	304	20	3	3	3	1	30-31,75-35-40-50-60	2600-4000
03 104 3040400 45	304	20	3	3	3	2	30-31,75-35-40-50-60	2600-4000
03 104 3040100 45	304	30	3	3	3	1	30-31,75-35-40-50-60	2600-4000
03 104 3040200 45	304	30	3	3	3	2	30-31,75-35-40-50-60	2600-4000

03 104 RICAMBI	Spare parts	Parte de repuestos	Ersatzteile
Codice	Descrizione		Dimensione
06 100 4510003		Tagliente Eurosystem	20x12x1,5mm
10 120 0000036		Tassello	17mm - 10°DX
10 120 0000037		Tassello	17mm - 10°SX
06 100 4510004		Tagliente Eurosystem	30x12x1,5mm
10 120 0000038		Tassello	27mm - 10°DX
10 120 0000039		Tassello	27mm - 10°SX
08 101 0506016		Vite fissaggio tagliente	M6x16 mm
06 100 7710201		Incisore quadrato	14x14x2mm
08 101 0305006		Vite incisore	M5x6mm
06 101 0000200		Supporto regolabile	12mm - DX
06 101 0000201		Supporto regolabile	12mm - SX
08 101 0105012		Grano fissaggio supporto	M5x12mm
06 117 7713300		Spigolatore MAN	5x16x22mm - 45°
06 117 7713301		Raggiatore MAN	5x16x22mm - R1,5
06 117 7713304		Raggiatore MAN	5x16x22mm - R3
08 101 0406012		Vite spigolatore/raggiatore	M6x12mm

DISCHI A TENONARE "GARNIGA"

Dischi a tenonare con taglienti EUROSYS-STEM in HM reversibili.

Gli spigolatori o i raggiatori sono montati su appositi carrelli scorrevoli che consentono di variare l'altezza di lavoro

"GARNIGA" TENONING DISKS

Tenoning disc with reversible EUROSYS-STEM HM inserts, the chamfer and radiusing knives mounted on special sliding slots allow the vertical position adjustment

DISCO PARA ESPIGAR "GARNIGA"

Disco para espigado con cuchillas EURO-SYSTEM en HM reversible.

Los biseladores y redondeadores son montados sobre soporte en el carril que permite regulación y variación en la altura de trabajo

VERZAPFSCHLEIBEN "GARNIGA"

Verzapfscheiben mit HM-EUROSYSTEM Wendeplatten.

Die Kantenbrecher oder Abrundmesser sind auf spezielle Haltern montiert um damit die gewünschte Arbeitshöhe einzustellen

03 104

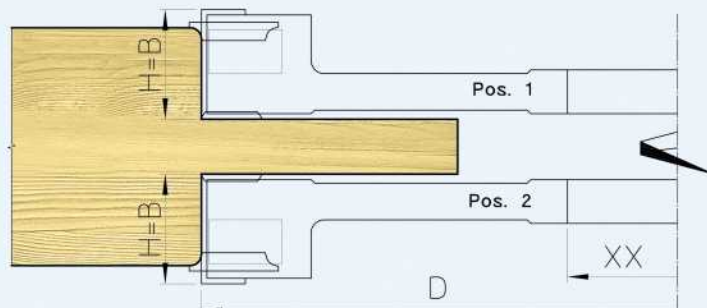

03 104 TENONARE Tenoning Espigado Zapfenbearbeitung

Type 02



Articolo	D	B	Z	V	XX	RPM min-max
03 104 2600700 45	260	8	3	3+3	30-31,75-35-40-50-60	3000-4500
03 104 2681100 45	268	8	3	3+3	30-31,75-35-40-50-60	2900-4400
03 104 2681000 45	268	12	3	3+3	30-31,75-35-40-50-60	2900-4400
03 104 2682700 45	268	15	3	3+3	30-31,75-35-40-50-60	2900-4400
03 104 2740100 45	274	8	3	3+3	30-31,75-35-40-50-60	2900-4400
03 104 2740200 45	274	15	3	3+3	30-31,75-35-40-50-60	2900-4400
03 104 2820800 45	282	8	3	3+3	30-31,75-35-40-50-60	2800-4200
03 104 2820700 45	282	15	3	3+3	30-31,75-35-40-50-60	2800-4200
03 104 2821300 45	282	12	3	3+3	30-31,75-35-40-50-60	2800-4200
03 104 3040500 45	304	8	3	3+3	30-31,75-35-40-50-60	2600-4000

03 104 RICAMBI	Spare parts	Parte de repuestos	Ersatzteile
Codice	Descrizione		Dimensione
06 100 4510000		Tagliente Eurosystem	7,5x12x1,5mm
10 120 0000003		Tassello	6mm
08 101 0504016		Vite fissaggio tagliente	M4x16 mm
06 100 4510012		Tagliente Eurosystem	11,5x12x1,5mm
10 120 0000004		Tassello	9mm
06 100 4510013		Tagliente Eurosystem	14,5x12x1,5mm
10 120 0000005		Tassello	12mm
08 101 0505016		Vite fissaggio tagliente	M5x16 mm
06 100 7710201		Incisore quadrato	14x14x2mm
08 101 0305006		Vite incisore	M5x6mm

DISCHI A TENONARE "GARNIGA"

Dischi a tenonare con taglienti EUROSYS-STEM in HM reversibili. Utilizzano l'innovativo sistema di fissaggio brevettato per un'ottima finitura

"GARNIGA" TENONING DISKS

Tenoning disk with reversible EUROSYS-STEM HM inserts. They use the new fixing system for a perfect finishing

DISCO PARA ESPIGAR "GARNIGA"

Disco para espigado con cuchillas EURO-SYSTEM en HM reversible. Utilizando el sistema de fijación nuevo para una óptima terminación

VERZAPFSCHEIBEN "GARNIGA"

Verzapfscheiben mit HM-EUROSYSTEM Wendeplatten. Mit dem neuesten Fixiersystem versehen um eine optimale Oberflächengüte zu erhalten

03 104

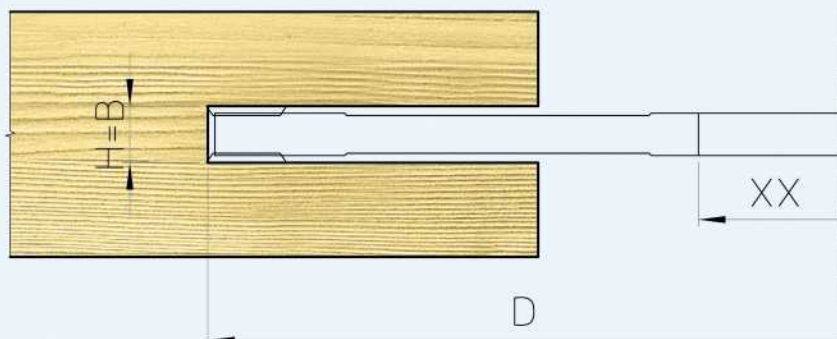

04 141 TENONARE Tenoning Espigado Zapfenbearbeitung



TESTA A TENONARE

Testa a tenonare, idonea per le macchine Wadkin, Robinson, Dominion.

Le teste sono costruite in una speciale lega leggera, che garantisce resistenza come i corpi in acciaio. Disponibili versioni inclinate.

Doppi incisori negativi per ottenere i migliori risultati di finitura

TENONING HEAD

Tenoning Heads with special sizes available to suit different machines types, Wadkin, Robinson, Dominion. Cutterhead made from top quality ALU. Light but same resistance as steel body. Special tapered version available.

Double negative spurs to obtain best quality finish results

CABEZAL DE ESPIGAR

Cabezal de espigar, idóneo para maquinas, Wadkin, Robinson, Dominion.

El cabezal esta construido en una aleación ligera especial, que garantiza la resistencia tanto como el acero. Disponible en versión inclinada.

Doble incisor negativo para obtener el mejor resultado y terminación

VERZAPFMESSERKOPF

Verzapfmesserkopf für den Einsatz auf Wadkin-, Robinson-, Dominion-Maschinen geeignet. Werkzeugmessenkopf besteht aus einer speziellen Leichtmetall-Legierung die dieselbe Festigkeitseigenschaften des Alu aufweist. Auch Schräg-Versionen sind vorhanden.

Mit doppelten Negativ-Vorschneidern versehen um eine optimale Oberflächengüte zu erreichen

Articolo	Rot.	Z	V	D	B	Tipo macchina	XX	RPM min-max
04 141 1701151 45	Dx	3	6	170	115	EC	31,75	4700-6800
04 141 1701152 45	Sx	3	6	170	115	EC	31,75	4700-6800
04 141 1701271 45	Dx	3	6	170	127	ECA	31,75	4700-6800
04 141 1701272 45	Sx	3	6	170	127	ECA	31,75	4700-6800
04 141 1701551 45	Dx	3	6	170	155	BXA	31,75	4700-6800
04 141 1701552 45	Sx	3	6	170	155	BXA	31,75	4700-6800
04 141 1901301 45	Dx	3	6	190	130	SC/E	38,1	4100-6200
04 141 1901302 45	Sx	3	6	190	130	SC/E	38,1	4100-6200
04 141 2001301 45	Dx	3	6	200	130	RP/E	31,75	3900-6200
04 141 2001302 45	Sx	3	6	200	130	RP/E	31,75	3900-6200
04 141 2161501 45	Dx	3	6	216	150	EKA	44,45	3600-5300
04 141 2161502 45	Sx	3	6	216	150	EKA	44,45	3600-5300

04 141 RICAMBI	Spare parts	Parte de repuestos	Ersatzteile
Codice	Descrizione		Dimensione
06 100 4510006		Tagliente Eurosystem	50x12x1,5mm
10 120 0000001		Tassello	47mm
06 100 4510007		Tagliente Eurosystem	60x12x1,5mm
10 120 0000002		Tassello	57mm
08 101 0506016		Vite fissaggio tagliente	M6x16 mm
06 100 7710201		Incisore quadrato	14x14x2mm
08 101 0305006		Vite incisore	M5x6mm

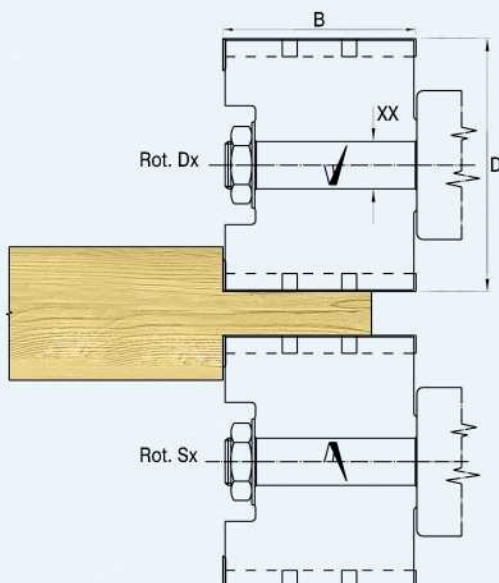

04 141

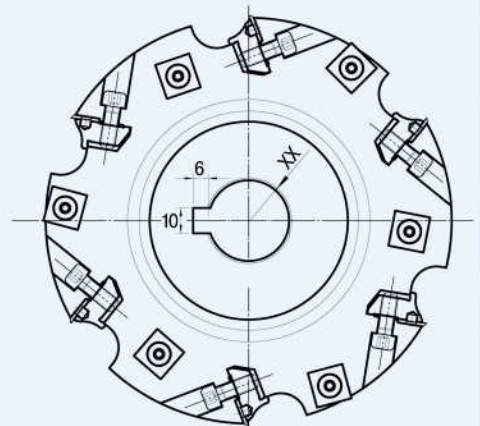

04 142 TENONARE Tenoning Espigado Zapfenbearbeitung



TESTA INCISORE PER MACCHINE A TENONARE

Testa incisore con limitatore di truciolo per macchine a tenonare conforme alle nuove normative per avanzamento MAN manuale, idonea per le macchine Wadkin, Robnson, Dominion. Accoppiate con il nostro prodotto Art. 04 141 sono di facile installazione e adattabili alle varie tipologie di macchine in quanto dotate del nuovo sistema QUICK-CHANGE

SCRIBING HEAD FOR TENONING MACHINE

Scribing heads for tenoning machine, ideal to combine with our Limiter tenoning Heads (see item Art. 04 141), special sizes available to suit different machines types, Wadkin, Dominion, Robnson. Easy setup with the QUICK-CHANGE system. One sleeve for all different cutters dimensions

CABEZAL INCISOR PARA MAQUINA DE ESPIGAR

Cabezal incisor con limitador de corte para maquina de espigar conforme a la nueva normativa para avance MAN manual, idóneo para maquinas, Wadkin, Robnson, Dominion. Acoplada con nuestro producto Art. 04 141 es fácil de instalar y adaptar a varios tipos de maquina en cuanto esta dotada del nuevo sistema QUICK-CHANGE

VORSCHNEIDERMESSERKOPF FÜR ZAPFENSCHNEIDER

Verzapfmesserkopf mit Spanabweiser gemäß dem neuesten Stand der Handvorschubnorm, für den Einsatz auf Wadkin-, Robnson-Dominion-Maschinen geeignet. Dieses Werkzeug ist mit Art. 04 141 kombinierbar und durch dem neuen QUICK-CHANGE System wird die Montage und Anpassungsfähigkeit vereinfacht

Articolo	Z	D	B	XX	RPM min-max	NOTE
04 142 1500030 60	2	150	30	60	3800-5600	Compatibile con QUICK-CHANGE
04 142 1500060 60	2	150	60	31,75-44,75	3800-5600	Cannotto integrato
04 142 1750030 60	2	175	30	60	3600-5300	Compatibile con QUICK-CHANGE
04 142 1750040 60	2	175	40	60	3600-5300	Compatibile con QUICK-CHANGE
04 142 1750050 60	2	175	50	31,75-44,75	3600-5300	Cannotto integrato
04 142 2250030 60	2	225	30	60	2700-4100	Compatibile con QUICK-CHANGE
04 142 2500030 60	2	250	30	60	2600-3800	Compatibile con QUICK-CHANGE
04 142 2750030 60	2	275	30	60	2300-3500	Compatibile con QUICK-CHANGE
04 142 3000030 60	2	300	30	60	2200-3100	Compatibile con QUICK-CHANGE

QUICK-CHANGE SYSTEM

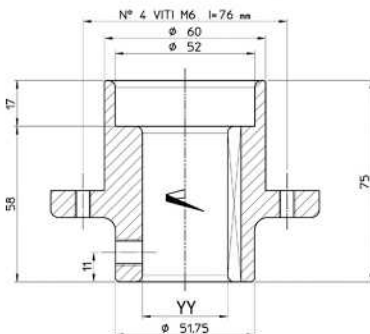

Articolo	YY	Chiavetta CxE
07 250 6032002	31,75	10x5
07 250 6030002	30	10x5
07 250 6035002	35	10x5
07 250 6038002	38,1	10x5
07 250 6038003	38,1	12x6
07 250 6040002	40	10x5
07 250 6040003	40	12x6

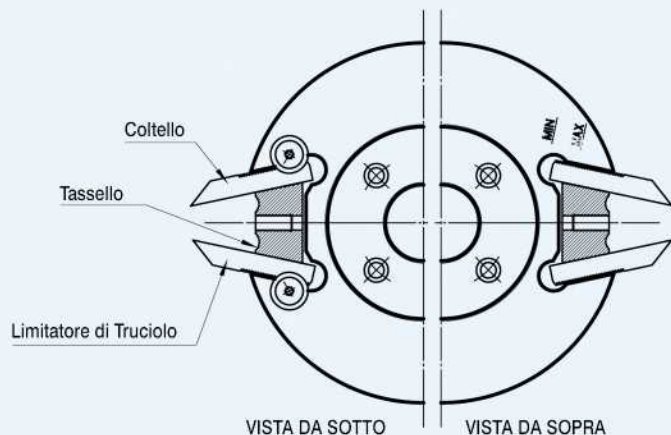
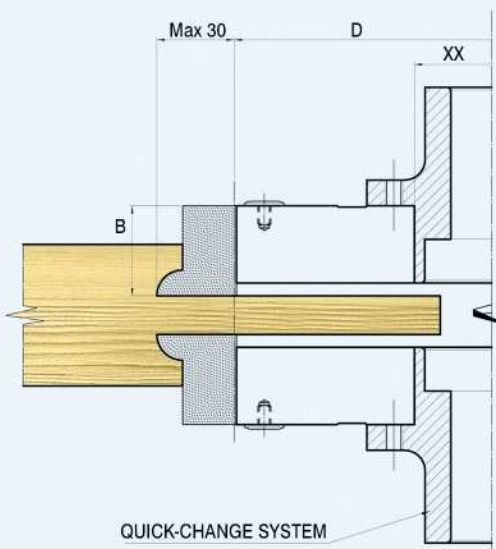

04 142

15 105 TENONARE Tenoning Espigado Zapfenbearbeitung



GRUPPO TENONATURA CASSAPORTA

Gruppi di tenoni montati su canotto per realizzare giunzioni di telai per porte

TENONING SET FOR DOORS JOINTS

Set of tenons mounted on sleeve for making door frame joints

GRUPO DE ESPIGADO DE CERCOS PARA PUERTAS

Grupo de platos de espigar montados sobre tubo para realizar la unión de cercos para puertas

TÜRENFRÄSERSATZ

Türenfräsersatz auf Büchse montiert für Rahmen-türverbindungen

Articolo	Rot.	Versione	XX	RPM min-max
15 105 1044300 45	Dx	Senza LS	30-31,75-35-40-50	2700-4100
15 105 1044310 45	Sx	Senza LS	30-31,75-35-40-50	2700-4100
15 105 1045300 45	Dx	LS	30-31,75-35-40-50	2700-4100
15 105 1045310 45	Sx	LS	30-31,75-35-40-50	2700-4100

15 105 RICAMBI	Spare parts	Parte de repuestos	Ersatzteile
Codice	Descrizione		Dimensione
06 100 9722042		Tagliante Eurosystem	19,6x12x1,5mm-45°
10 120 0000006		Tassello	17mm
08 101 0506016		Vite fissaggio tagliante	M6x16 mm
06 100 7710201		Incisore quadrato	14x14x2mm
08 101 0305006		Vite incisore	M5x6mm
06 117 7713300		Spigolatore MAN	5x16x22mm - 45°
06 117 7713301		Raggiatore MAN	5x16x22mm - R1,5
06 117 7713304		Raggiatore MAN	5x16x22mm - R3
08 101 0406012		Vite spigolatore/raggiatore	M6x12mm

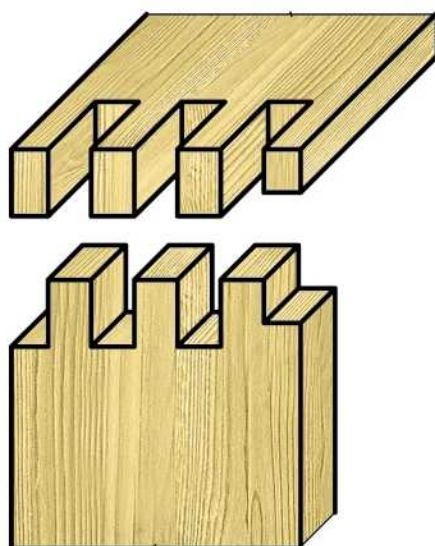

15 105



Versione senza LS

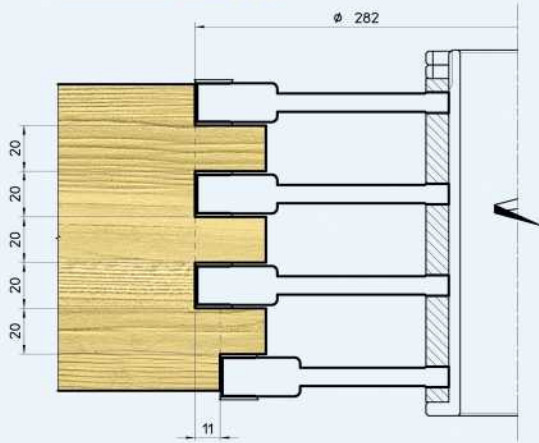

Versione con LS

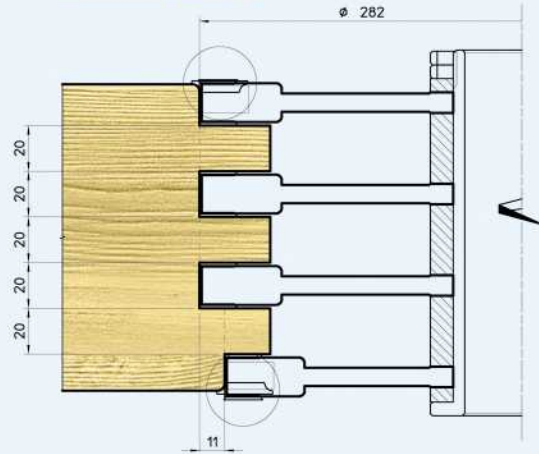

GIUNZIONI

Variante 01

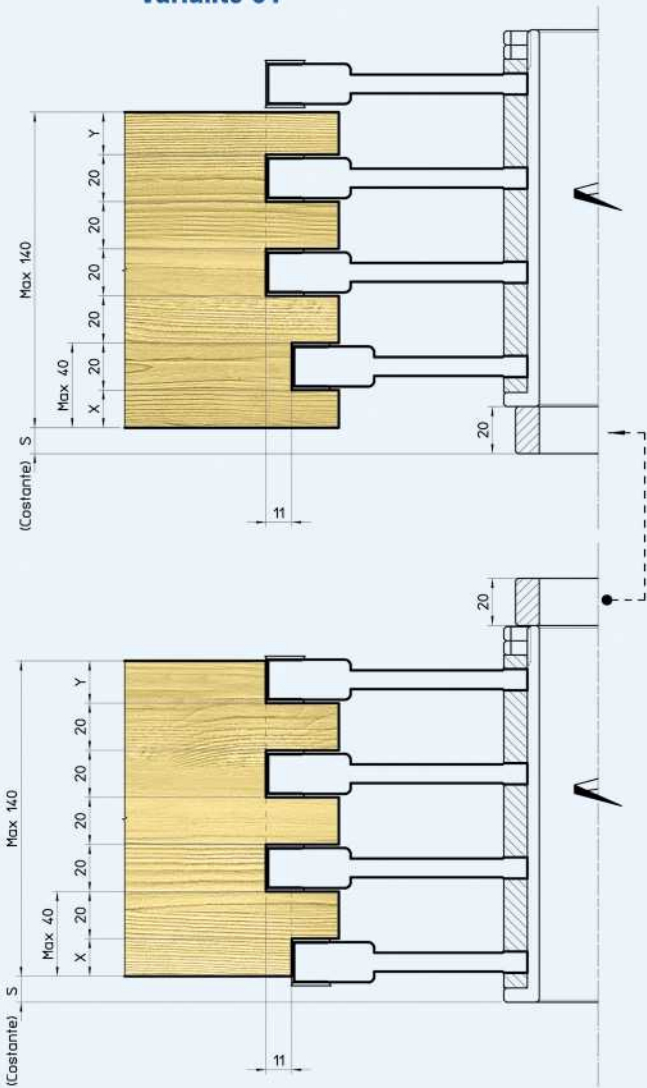

Variante 02

